

DETAIL-FS1

- BOLTED DIRECTLY TO STEEL
- 600mm-1200mm REQUIRES BRACING

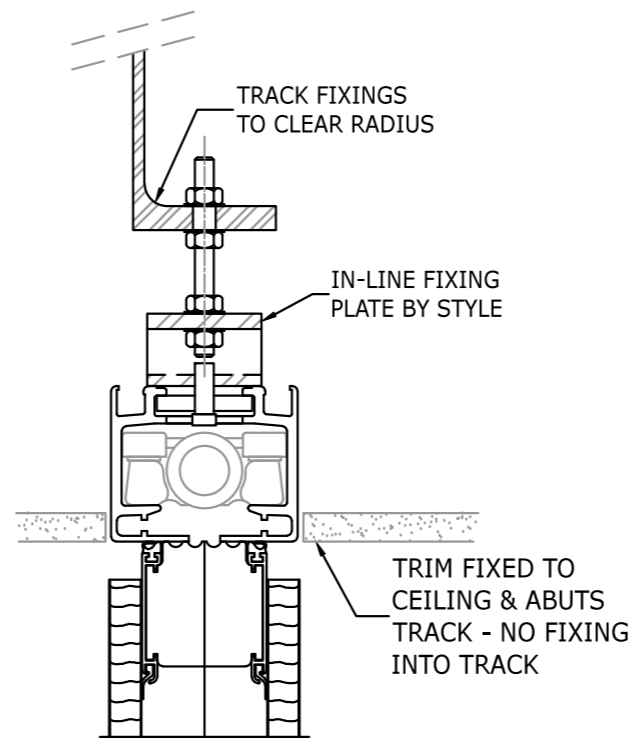

DETAIL-FS2

- FIXINGS BOLTED IN-LINE TO CHANNEL

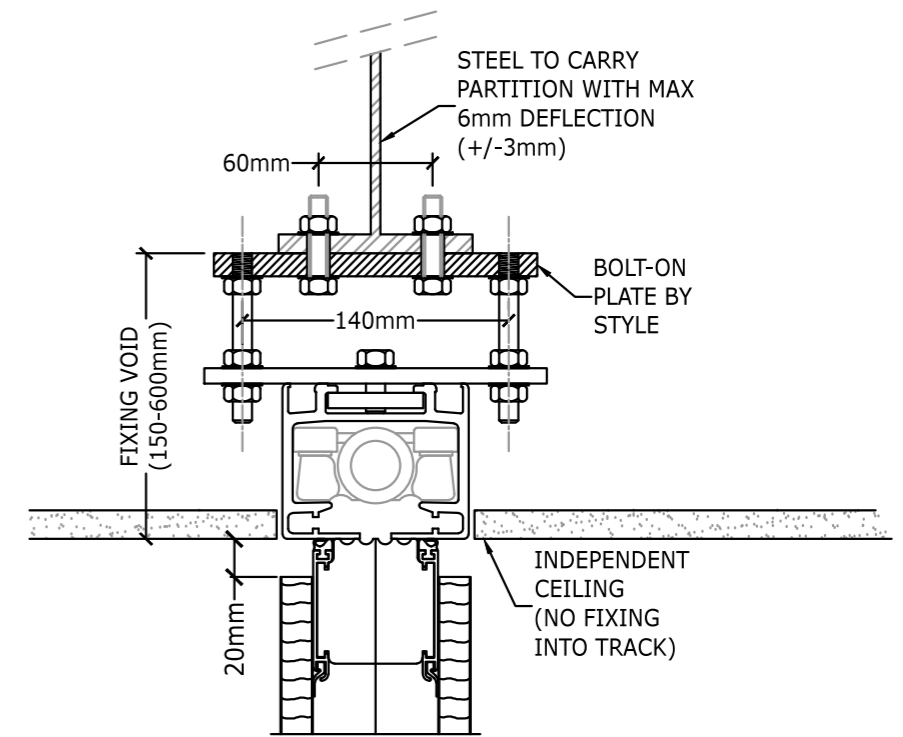

DETAIL-FS3

- BOLT-ON PLATE TO NARROW STEEL
- 600mm-1200mm REQUIRES BRACING

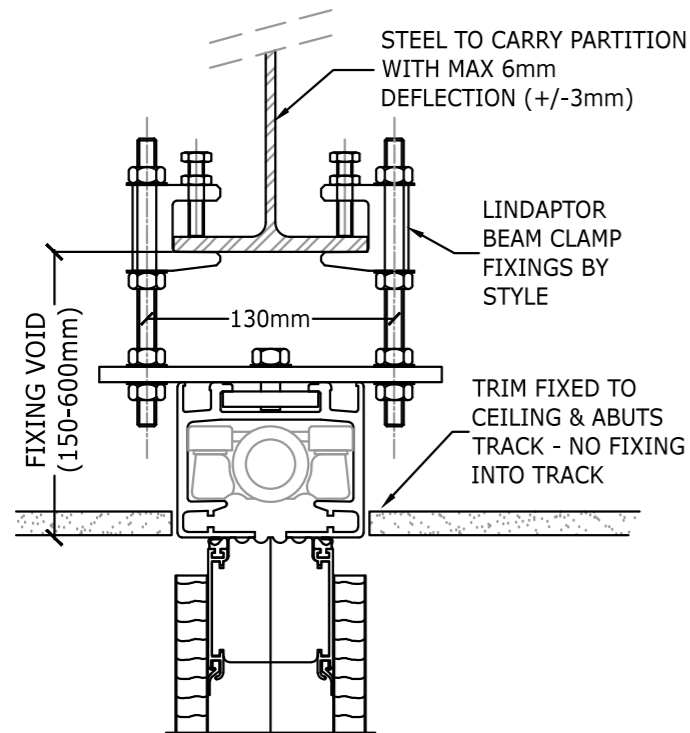

DETAIL-FS4

- EDGE-CLAMP TO NARROW STEEL
- 600mm-1200mm REQUIRES BRACING

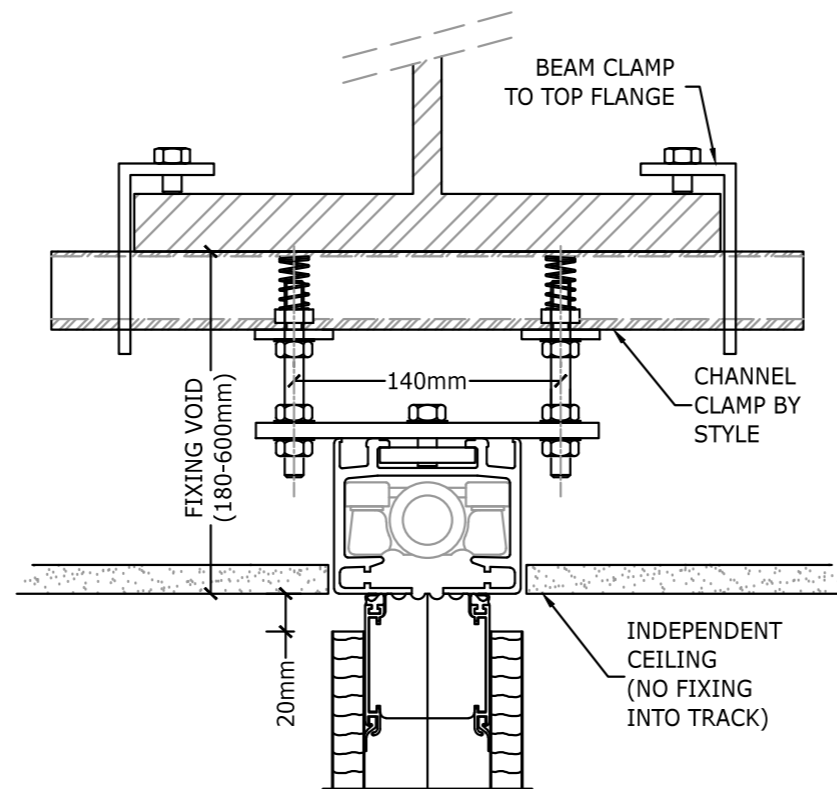

DETAIL-FS5

- CLAMPED TO THICK STEEL
- 600mm-1200mm REQUIRES BRACING

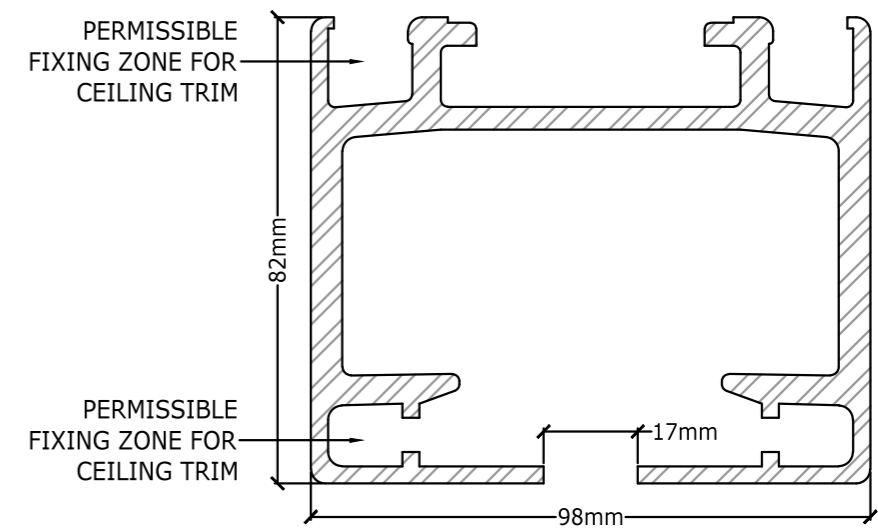

TYPE-R HEAD TRACK

	Datum	Name	Info-Zeichnung	
Bearb.				
Gepr.			Zeichnungs-Nr:	Maßstab
Norm				
DORMA Hüppe MOBILFAL Hungária Kft. Rétkőz utca 5. 1118 Budapest Telefon +36.30.274.1010			Layout: LAYOUT	
			Ersatz für ERSATZ	